

COMBi-WR4

Pedestrian Reach Stacker

The first purpose built 4-way pedestrian reach stacker combining multi-directional travel, innovative features and effortless operation.

COMBiLiFT

LIFTING INNOVATION



Patented Multi-Position
Tiller Arm

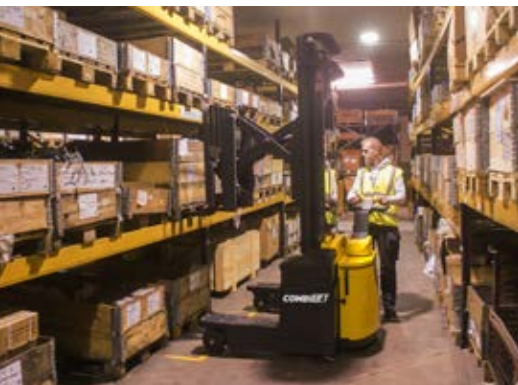

TotalTruck A/S

totaltruck@totaltruck.dk



COMBI-WR4

Pedestrian Reach Stacker

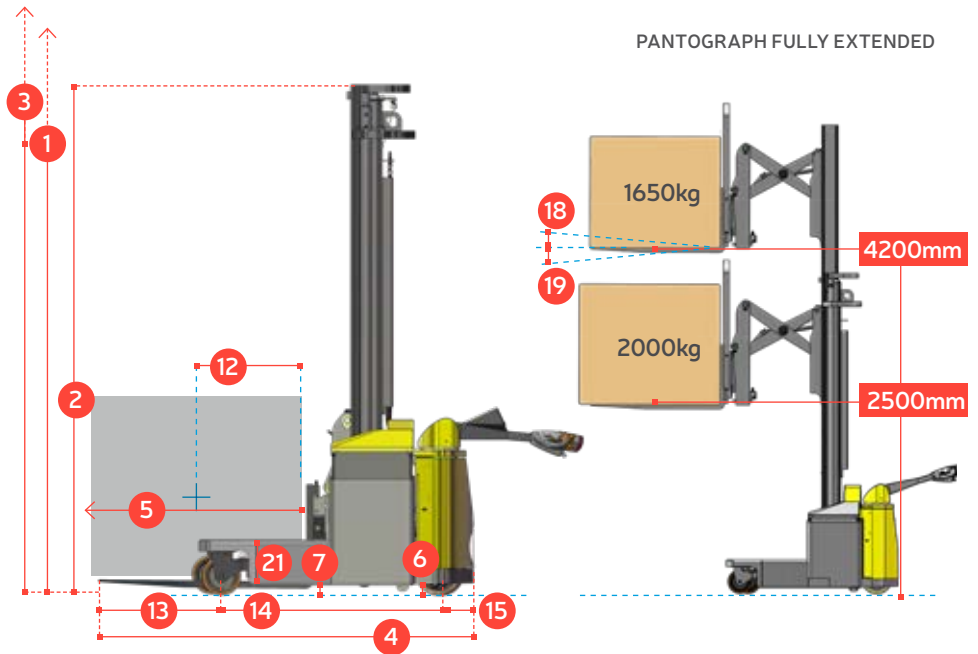
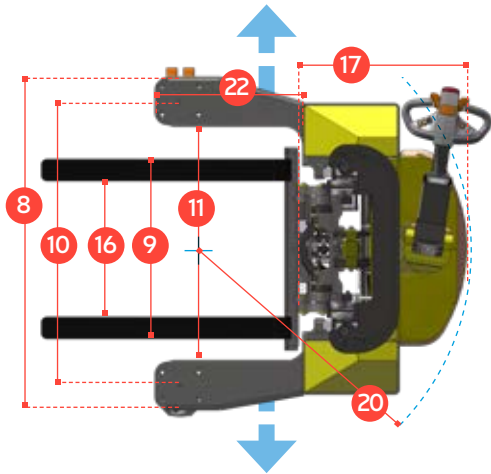

PANTOGRAPH FULLY EXTENDED

REF.	DESCRIPTION	STD.	OPTIONAL	
1a	Standard Lift Height	3000 mm	4200 mm	4900 mm
1b	Free Lift Height	900 mm	1500 mm	1850 mm
2	Height Mast Closed	2100 mm	2700 mm	3050 mm
3	Max. (Mast Raised)	4200 mm	5400 mm	6100 mm
4	Overall Length		2125 mm	
5	Fork Travel		590 mm	
6	Ground Clearance Under Mast		80 mm	
7	Ground Clearance to Centre of Wheelbase		50 mm	
8	Width		1512 mm	
9	Outside Spread of Fork Arms		815 mm	
10	Track Front		1292 mm	
11	Frame Opening		1058 mm	
12	Load Centre Distance		600 mm	
13	Overhang Front		655 mm	
14	Wheelbase		1220 mm	
15	Overhang Back		175 mm	
16	Fork Side Shift		80 mm Left / 80 mm Right	
17	Length from Face of Fork		1055 mm	
18	Fork Backward Tilt		3°	
19	Fork Forward Tilt		3°	
20	Minimum Outside Radius		1350 mm	
21	Leg Height		282 mm	
22	Leg Length		455 mm	
A	Capacity		2000kg @ 2500mm Lift	
B	Unladen Weight	2850 kg	2950 kg	3050 kg
C	Maximum Ground Speed		6 km/h	
D	Gradeability		5 %	
E	Battery Capacity		24V / 420 Ah	
F	Fork Section		40mm x 100mm x 1070mm	
G	Front Tyre x 4 (Polyurethane)		OD 200mm / Width 50mm	
H	Rear Tyre (Vulkollan)		OD 250mm / Width 75mm	
I	Standard Colour		Yellow & Grey	
J	AC Electric Traction Motor		24 V / 2.5 kW	
K	AC Electric Pump Motor		24 V / 5 kW	

Superior safety with Combilift's patented Multi-Position Tiller Arm

The tiller can be turned to the left or right to allow the operator to remain at the side. This enables full visibility of the load and forks, while maintaining full steering control, providing greater awareness of the surroundings for enhanced overall safety.

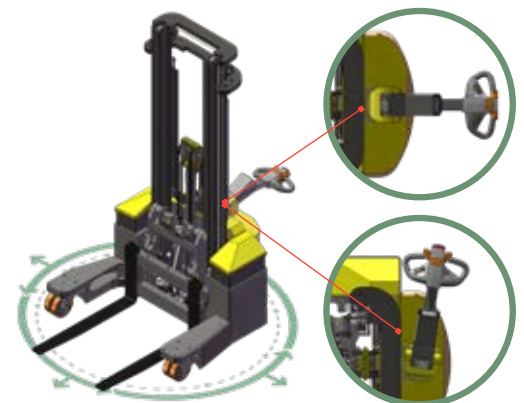

Features Include:

- Pantograph
- Power Steering
- AC Motor Technology
- 1200mm High Load Back Rest
- Rear Wheel Drive
- 80/80mm Side Shift
- Patented Multi-Position Tiller Arm

Distributed by:



TotalTruck A/S

CVR-nr. DK 26 12 66 22

Lucernetoften 5 · 5550 Langeskov
Tlf. +45 70 27 99 88

Standing to the side of the stacker eliminates the risk of being trapped or crushed whilst allowing the Combi-WR to operate in very narrow aisles.

Using Combi-WR4

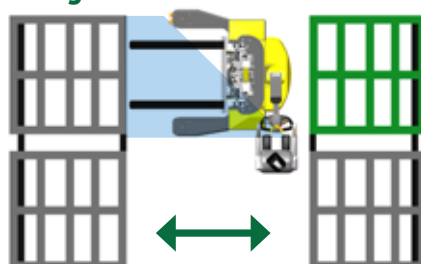

International Application No. PCT/EP2012/067238 Multi Position Tiller; GB Patent No. 2531778; International Patent Application No. PCT/EP2015/074906.

TotalTruck A/S

totaltruck@totaltruck.dk

