

# C-SERIES C14,000

The multi-directional forklift designed for the safe, space saving and productive handling of long and bulky loads.

# COMBILIFT

LIFTING INNOVATION



C-serie presentation



# C-SERIES C14,000

## FRONTAL MODE

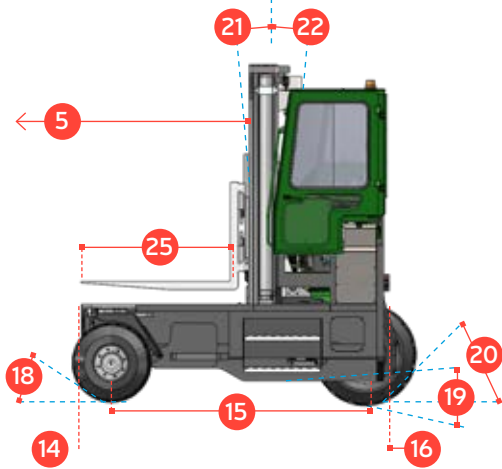

## SI DEWARD MODE

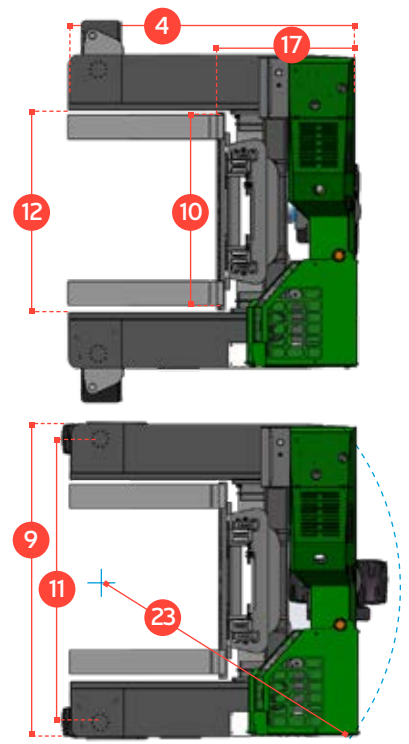
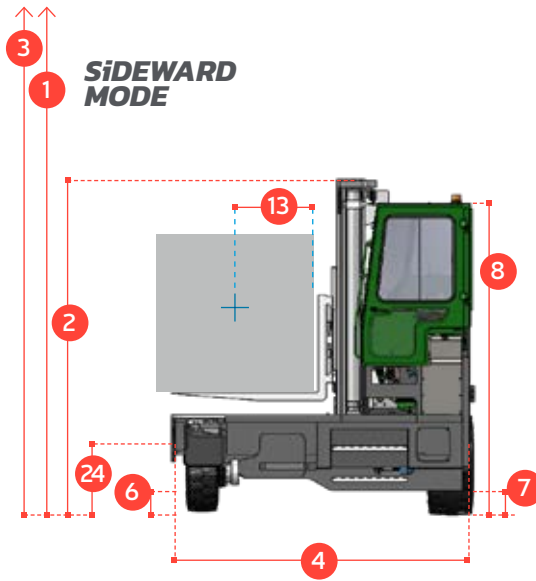

REF.	DESCRIPTION	C14,000
1a	Max. Lift Height	4100mm
1b	Freelift Height	0mm
2	Height Mast Closed	3450mm
3	Max. (Mast raised)	5800mm
4	Overall Length	3040mm
5	Mast Travel	1650mm
6	Ground Clearance Under Mast	305mm
7	Ground Clearance to Centre of Wheelbase	330mm
8	Height Over Cab (Without work lights)	3180mm
9	Width	3510mm
10	Outside Spread of Fork Arms	2050mm
11	Track Front	3190mm
12	Frame Opening	2210mm
13	Load Centre Distance	600mm
14	Overhang Front	305mm
15	Wheelbase	2550mm
16	Overhang Back	185mm
17	Length From Face of Fork	1550mm
18	Approach Angle	45°
19	Ramp Angle	29°
20	Departure Angle	45°
21	Forward Tilt	4°
22	Backward Tilt	8°
23	Minimum Outside Radius	3250mm
24	Platform Height	980mm
25	Platform Length	1490mm

A	Capacity	14000kg
B	Unladen Weight	16500kg
C	Maximum Ground Speed	15 km/h
D	Gradeability	15%
E	John Deere 4045 Diesel Engine	93 kW (125 HP)
F	Electrics	12 Volt
G	Fork Section	65mm x 250mm x 1490mm
H	400 / 60 – 15 Front Tyre	OD 825mm / Width 326mm
I	465 / 55 - 20 Rear Tyre	OD 1030mm / Width 465mm
J	Standard Colour	Green & Grey
K	Suspension Seat	KAB Model 116

## Multi-Directional

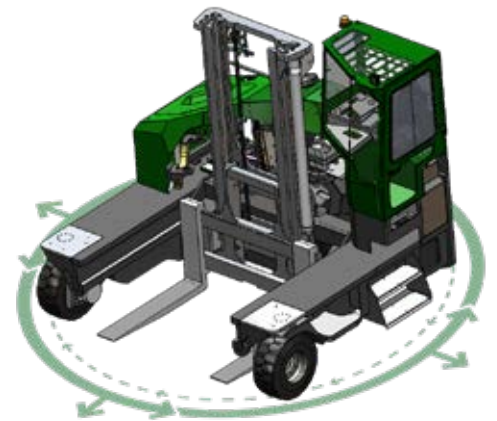

## Features Include:

- Rubber Mounted Half Open Cabin
- Multi-Directional Operation
- 3 Wheel Hydrostatic Drive
- Load Sensing Steering
- 4 Way Lever Positioning of Wheels
- Hydraulic Oil Cooler

## Distributed by:



TotalTruck A/S

CVR-nr. DK 26 12 66 22

Lucernetofte 5 · 5550 Langeskov

Tlf. +45 70 27 99 88

European Patent No. 2167416; Brazilian Patent No. P10811954-6; Australian Patent No. 2008253242