

# WPio12

Lithium-Ion Hand Pallet Truck  
Electrical Lift and Electrical Drive System  
1.200 kg

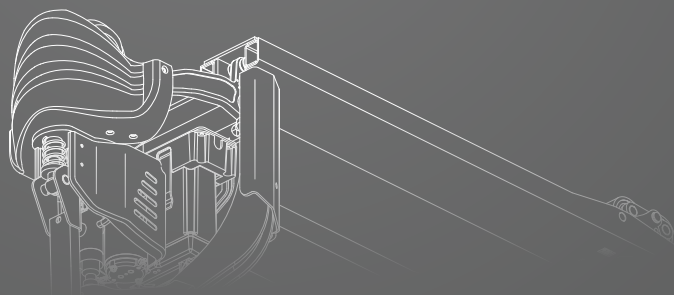
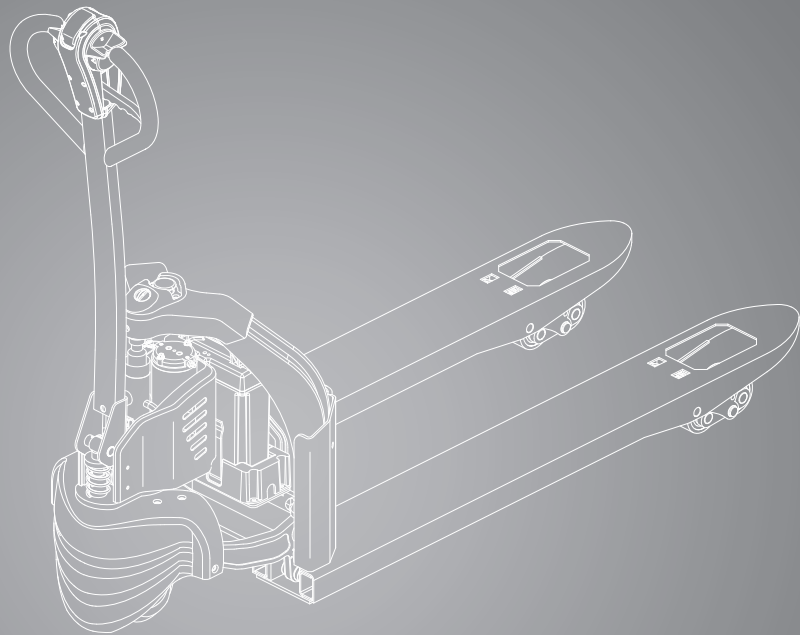

# DIMENSIONS

$$R_h = \sqrt{x^2 + \left(\frac{b_{12}}{2}\right)^2}$$

$$A_{st} = W_a + l_6 - x + a \quad \text{if } R_h < W_a$$

$$A_{st} = R_h + l_6 - x + a \quad \text{if } R_h > W_a$$

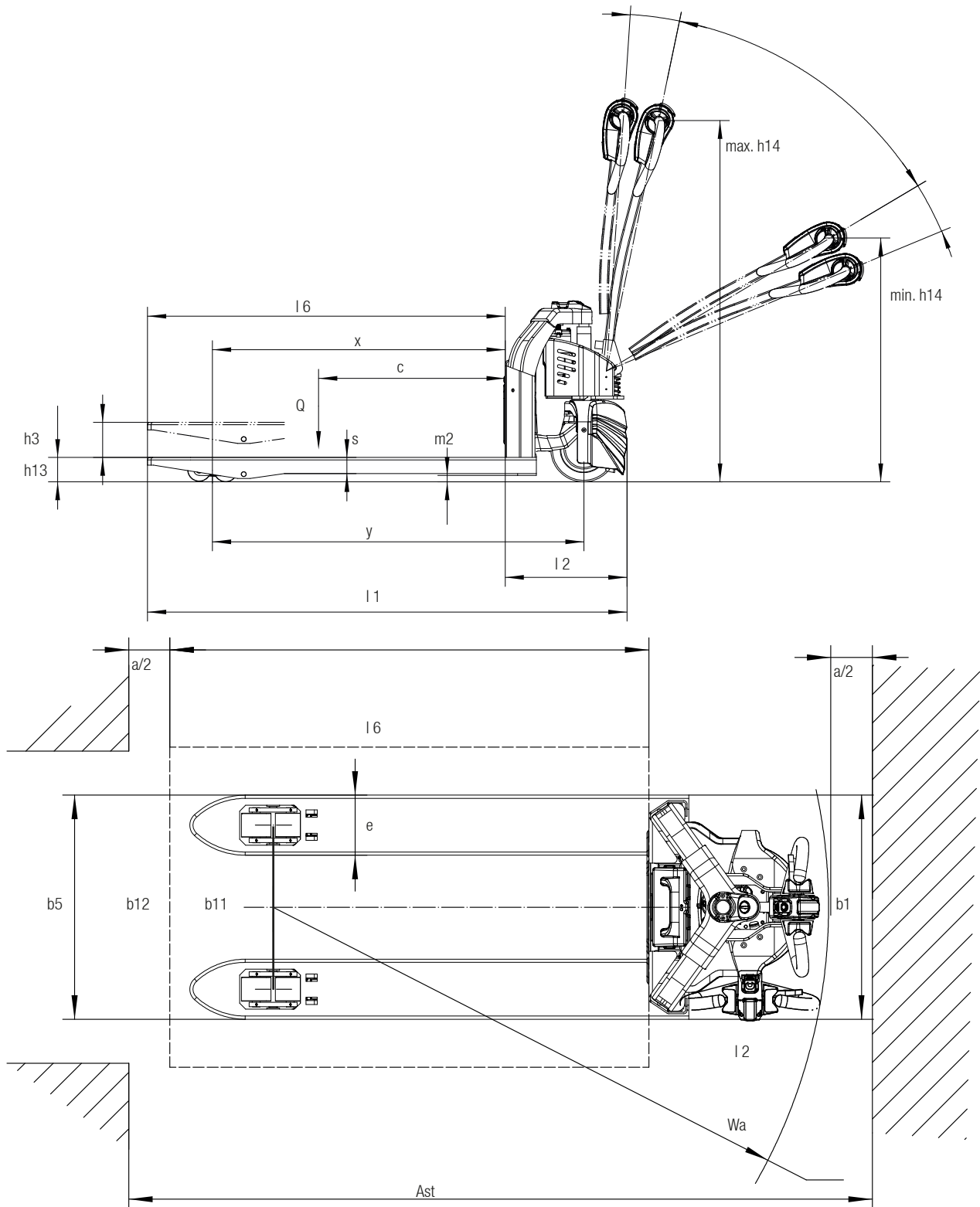

For corresponding data see specification chart.

# SPECIFICATIONS

## Product Specification acc. to VDI 2198

1.1 Manufacturer (Abbreviation)		CLARK
Specifications	1.2 Manufacturer's designation	<b>WPio12</b>
	1.3 Drive	24V Electric
	1.4 Operator type	Pedestrian
	1.5 Rated capacity/rated load	Q (kg) 1200
	1.6 Load centre distance	c (mm) 600
	1.8 Load distance	x (mm) 950
	1.9 Wheelbase	y (mm) 1190
Weight	2.1 Service weight incl. battery (see 6.5)	kg 130
	2.2 Axle loading, laden front/rear	kg 420/910
	2.3 Axle loading, unladen front/rear	kg 110/20
Tyres, Chassis	3.1 Tyres	Polyurethane
	3.2 Tyre size, front	Ø 210x70
	3.3 Tyre size, rear	Ø80x60
	3.4 Additional wheels (dimensions)	-
	3.5 Wheels, number front/rear (x = driven wheels)	1x / 2 or 4
	3.6 Tread, front	b10 (mm) -
	3.7 Tread, rear	b11 (mm) 410
Dimensions	4.4 Lift	h3 (mm) 115
	4.4 Lift height	h3 + h13 (mm) 195
	4.9 Height tiller in driving position min./max.	h14 (mm) 750/1190
	4.15 Height, lowered	h13 (mm) 80
	4.19 Overall length	l1 (mm) 1540
	4.20 Length to face of forks	l2 (mm) 390
	4.21 Overall width	b1 (mm) 560
	4.22 Fork dimensions	s • e • l (mm) 53x150x1150
	4.25 Distance between fork-arms	b5 (mm) 560
	4.32 Ground clearance, centre of wheelbase	m2 (mm) 27
	4.33 Aisle width for pallets 1000 x 1200 sideways	Ast (mm) 1640
4.34 Aisle width for pallets 800 x 1200 lengthways	Ast (mm) 1840	
4.35 Turning radius	Wa (mm) 1390	
Performance	5.1 Travel speed, laden/unladen	km/h 4,0/4,5
	5.2 Lift speed, laden/unladen	m/s 0.02/0.025
	5.3 Lowering speed, laden/unladen	m/s 0.06/0.03
	5.8 Max. gradeability, laden/unladen *1	% 4/10
	5.10 Service brake	Electric
Electrics	6.1 Drive motor rating S2 60 min	kW 0.65
	6.2 Lift motor rating at S3 15 %	kW 0.5
	6.3 Battery acc. to DIN 43531/35/36 A, B, C, no	No
	6.4 Battery voltage/nominal capacity (Option)	Ah 24 / 20 (26)
	6.5 Battery weight	kg 3.7
	6.6 Energy consumption acc. to VDI cycle	kWh/h 0.25
	- Battery type	Lithium-ion
8.1 Type of drive unit	DC	
Misc.	10.5 Steering design	Mechanical
	10.7 Sound pressure level at the driver's seat acc. to EN 12053	dB(A) <64

\*1) At friction coefficient  $\mu=0.6$  with 1.6 km/h

# EQUIPMENT EXTRAS

		WPio12
General	Easy to handle lithium-ion battery (3.7 kg)	•
	Truck net weight, including battery 130 kg	•
	External charger	•
	Electrical lift and electrical drive system	•
Drive Options	Tandem load wheel (polyurethane)	•
	Single load wheel (polyurethane)	X
	Replacement lithium-ion battery	X
	Battery discharge indicator	•
Fork Options	Fork length 1000 mm, 1150 mm or 1220 mm	X
	Width across forks 560 mm	•
	Width across forks 685 mm	X
Safety	Key switch activation via Smart Key	•
	Monitored by battery management system	•
	Automatic lift stop at maximum lift	•
	Gradient Anti-Roll-Back	•
	Automatic parking brake	•
	Belly switch	•

• = Standard Equipment; x = Option

# FEATURES & ADVANTAGES

## WPio12

### Electrical lift and manual lowering

- Sensitive lifting and lowering
- Drive and operating switches with easy reach position
- Automatic lift stop (at maximum lift)

### Smart Display

- Battery discharge indicator
- Operating hour counter
- Battery management system
- On-board diagnostics via error codes

### Smart Key

- Smart-Key activation
- Easy to use
- Access control

### Application

- Specially developed for use on level ground
- Ideal for slight gradients of maximum 4 degree
- Always usable with the lithium-ion battery from top-up charging
- Quick charging times
- Maneuverability in tight corners
  - Total width (b1) only 560 mm
  - Length to fork face (l2) only 390 mm

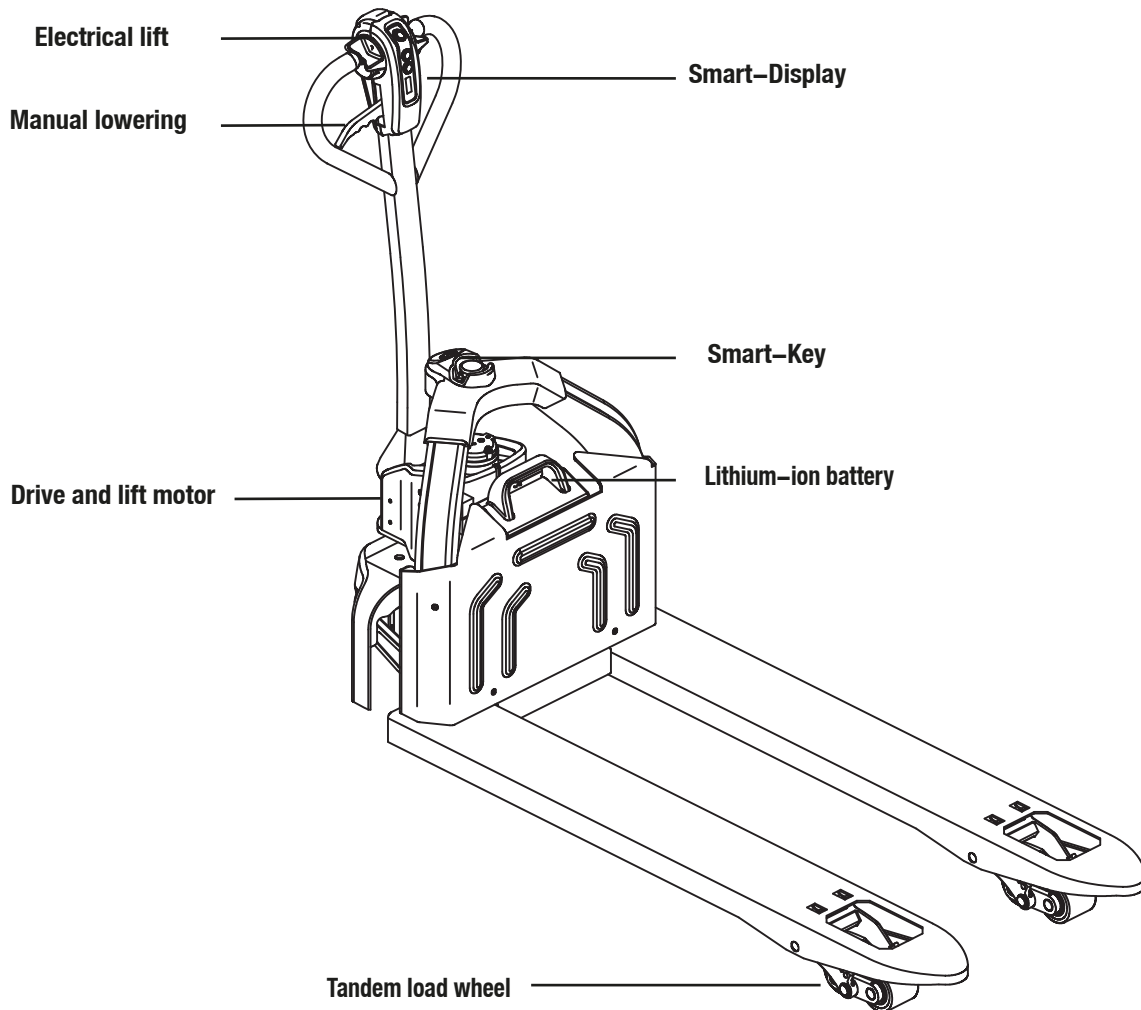

## WPio12

### The WPio12 – an innovative assistant

The WPio12 is an electric hand pallet truck with a lithium-ion battery. It is ideal for transporting all kinds of goods over short distances. In contrast to conventional hand pallet trucks, the WPio12 lifts and moves goods using electrical power. The minimal L2 dimension (length to face of forks) of only 390 mm, makes the WPio12 extremely compact and ideal for use in confined spaces, e.g. in stores and business centres of all types.

Its low service weight of only 130 kg is a further advantage that also allows the WPio12 to be transported in lorries and used on tail lifts.

Thanks to the maintenance-free lithium-ion battery and the included charger daily routines stay much the same when a conventional hand pallet truck is replaced with the WPio12. The WPio12 is perfect for light duties in goods distribution, production tasks or warehouse applications – an innovative assistant.

### Advantages of lithium-ion technology in the WPio12

#### High performance in a compact design

The high energy density of the installed lithium-ion battery provides great travel performance and long operating periods of up to 3 hours. At the same time, the WPio12 is very compact and has a low service weight, which means it consumes up to 30 % less energy than vehicles with lead-acid batteries.

#### Fast charging + top-up charging

Top-up charging can be used between full charges without affecting the service life of the battery. The battery can be recharged with any 230-V socket. No costs are incurred for adapting the existing charging infrastructure (e.g. ventilation).

After deep discharge cycle, charging to 60% battery capacity takes only 40 minutes and the battery is charged to full capacity after 2.5 hours.

#### Double service life + maintenance-free battery

The lithium-ion battery has approximately twice the service life of a conventional lead-acid battery (approximately 1,000 charge cycles). Furthermore, it does not require any maintenance with regard to battery acid.

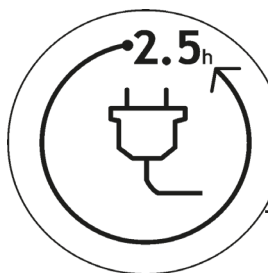

Rapid charging,  
fully recharged  
within only  
2.5 h

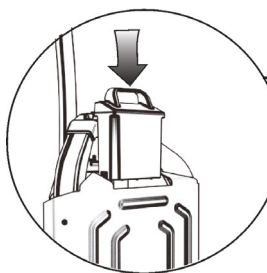

Lithium-ion  
battery weight of  
only 3,7 kg

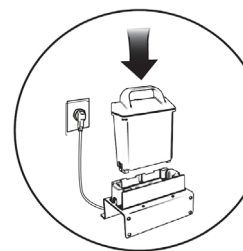

Charging at  
any standard  
230 V socket

CLARK Europe GmbH  
Dr.-Alfred-Herrhausen-Allee 33  
47228 Duisburg / Germany  
Tel.: +49 (0)2065 499 13-0  
Fax: +49 (0)2065 499 13-290  
E-Mail: [Info-europe@clarkmheu.com](mailto:Info-europe@clarkmheu.com)  
[www.clarkmheu.com](http://www.clarkmheu.com)

Dealer:



TotalTruck A/S

CVR-nr. DK 26 12 66 22

Lucernetoften 5 · 5550 Langeskov  
Tlf. +45 70 27 99 88